

SÜDLUFT

SYSTEMTECHNIK

AIR DUCT SYSTEMS
Air guidance-perfection

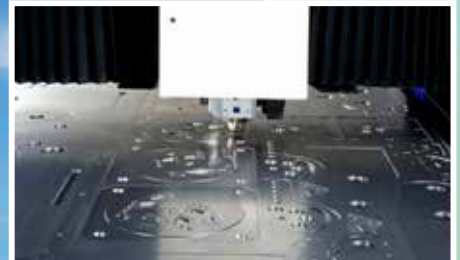

SÜDLUFT SYSTEMTECHNIK
LOCATED IN PLATTLING
(IN THE HEART OF BAVARIA)



SÜDLUFT
SYSTEMTECHNIK

CONTENTS

The company SÜDLUFT	4-5
CAD/3D and production capacities	6-7
Modular duct	8-12
Explanation / patent	8-10
Split design	11
Final assembly screwed	12
Final assembly welded	12
Pipes	13
Lock-seam ducts	14
Accessories	15-16
Services	17
Components for plant engineering	18-19
Work decks	18
Sheet metal/cabin enclosures	19
Air showers	19
Duct order list	20-21

INTRODUCING AN INNOVATIVE COMPANY

The name SÜDLUFT guarantees quality in the ventilation technology sector – and has done so for decades. The advantages for our customers lie in the planning, design, production and assembly of our ventilation components, all from one source.

The range of successfully completed projects and our customer satisfaction highlights this spectacularly.

As a reliable partner of plant engineers in a wide range of industries, we know the requirements of modern air duct systems and fulfill them time and time again.



MADE IN GERMANY –
FROM PLANNING
AND IN-HOUSE
MANUFACTURING
TO ON-SITE
ASSEMBLY.

OUR BUSINESS FIELDS

AIR DUCT SYSTEMS

Customers are primarily plant engineering companies in the automotive industry, environmental technology, paper industry, chemical and pharmaceutical industry. This sector is defined by the “modular duct”. This is a patented gas-tight duct system which has been specially developed for exhaust air management in automotive paint shops and it meets the highest demands.



VENTILATION TOWERS AND COMPONENTS FOR CLEANROOM AREAS

This sector comprises air towers, air showers for cleanrooms and particulate filters with installation openings.



KITCHEN VENTILATION TECHNOLOGY (EXTRACTOR CEILING AND HOODS)

At the forefront of this sector is the manufacture, supply and assembly of ceiling ventilation systems for industrial kitchens adapted to the individual structural conditions. Extractor hoods for industrial kitchens are manufactured in standard designs and as individual solutions.



THE LATEST SOFTWARE AND HIGH TECHNOLOGY-BASED PRODUCTION CAPACITIES



CAD AND 3D WORKPLACES

With our 2D CAD i.e. 3D workplaces, which are fitted with the latest software, we carry out the implementation process even for demanding large-scale projects.



DECOILING PLANTS

The cut-to-length line, manufactured to perfectly fit our requirements, enables the sheets for our product range to be decoiled with millimetre precision.



LASER CUTTING SYSTEMS

Our computer-controlled laser cutting machines are able to cut sheet metal up to 20 mm thickness.

1x TruLaser 3040

Working area:
4000 x 2000 mm,
Laser power: 4 kW

1x TruLaser 3030 (L20)

Working area:
3000 x 1500 mm,
Laser power: 5 kW



BENDING MACHINE

3 hydraulic bending machines with bending lengths of 4 m, 4.5 m and 6 m make it possible for us to process sheets up to 6 m long and 6 mm thick.



SHEET METAL ROUNDING MACHINE

With our round bending machine we have the possibility to bend metal sheets into pipes with a diameter of 250 mm to 1600 mm.

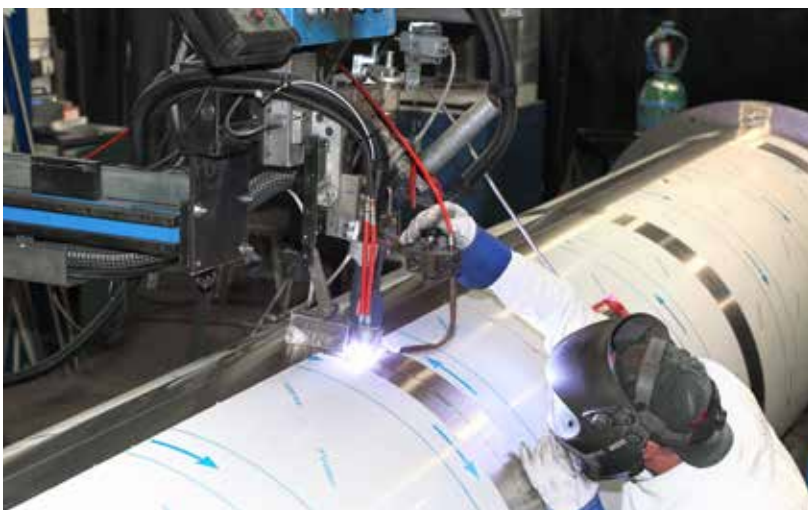

WELDING MACHINE

On our circular and longitudinal seam welding machines we are able to weld pipes with a diameter of 250 mm to 1600 mm in a highest maximum quality standard.

SL MODULAR DUCT – VARIABLE, IMPRESSIVE, CONTEMPORARY.

The SL modular duct is a patented gas-tight duct system which has been specially developed for exhaust air ducting in the paint shops of the automotive industry and it meets the highest requirements for air tightness, resistance to corrosion, ease of assembly and even visual appearance.

SL MODULE – THE PATENT IS YOUR PROFIT

SL MODULE is the patented air duct system for industry and trade. It is a worldwide unique method of manufacturing and assembling air duct elements cost-effectively, on time and in the highest quality. The manufacturing process is carried out without the need for damaging welded seams. With wall thicknesses up to 1.5 mm and air tightness class D (DIN EN 1507) there are no restrictions to design. Round and square elements as well as various special shapes, which are screwed together on site, are what makes up the unsurpassed flexibility of the SL MODULE. Accessories such as deflector hoods, intake hoods, sound absorbers, access and inspection doors, louvre and regulating dampers complete the range.



SL MODULAR DUCT

–
IMPRESSIVE IN
EVERY WAY!

IMPRESSIVE QUALITY FEATURES:

- extreme air-tightness thanks to the folded panel system design
- low duct friction losses thanks to smooth inner duct walls
- high pressure stability even with thin-walled ducts thanks to the folded panel system design
- high corrosion resistance of galvanised materials thanks to the reduction of welding seams
- easy assembly thanks to lightweight flat packed, bolted/screwed construction
- largest freight capacity due to the flat packed components

SL MODULAR DUCT DESIGN:

- longitudinally split duct with bolted/screwed flanges and folded external stiffeners further strengthen the duct wall
- screwing/bolting of the panel flanges designed with bolt hole spacing of 100 mm for M8 screws – standard (other options available)
- thanks to corner and adapter parts, any length is possible
- reinforcement of the outer walls of the duct by welded and stiffening profiles
- easy insulation possibilities thanks to the use of Z-profiles
- additional reinforcement for larger ducts through internally mounted support tubes available in screwed or welded design
- delivery of the duct bends in flat pack form depending on size
- if required, climbing rungs or ladders in vertical duct pipes, which can also serve as supports for scaffolding platforms during cleaning and maintenance works
- delivery in flat pack form, screwed/bolted together during assembly



MATERIALS

Following materials are used:

Material	Material no.
Galvanised steel	DX51D + Z275MAC (1.0226)
Carbon steel	S235JR + AR
Stainless steel V2A	1.4301 / 1.4307 / 1.4541
Stainless steel V4A	1.4571 / 1.4404
Aluminized	DX51D + AS 120 (1.0226)

Sheet thickness 1.0 to 3.0 mm.

Other sheet thicknesses and materials available on request.

RECOMMENDED WALL THICKNESSES FOR SL MODULAR DUCTS

Pressure class	Low pressure (N)	Medium pressure (M)	High pressure (H)
Max. pressure resistance [Pa]	-500 / +1000	-750 / +2000	-2500 / +6000
Edge length 200 to 800 [mm]	1.00	1.00	2.00
Edge length 900 to 2000 [mm]	1.25	1.50	2.00
Edge length 2100 to 4000 [mm]	1.50	2.00	2.00 with internal reinforcement
Edge length 4100 to 8000 [mm]	1.50 with internal reinforcement	2.00 with internal reinforcement	2.00 with internal reinforcement
Edge length above 8000 [mm]	Determined in accordance with the respective requirements		

TESTED QUALITY

Excerpts from TÜV reports

Results of the inspection by TÜV Bayern e. V.
 Südluft Systemtechnik GmbH, Plattling, Industriepark
 G3-WUW 30-wb-os A.-Nr. 144 5537
 09.02.1989 Sheet 3



For the metal duct SL module system by Südluft Systemtechnik GmbH in 94447 Plattling:

- Test pressure 200 Pa: The measurement was discontinued without results; a leakage air volume flow could not be detected. Leakage air flow < 0.002 m³/h.
- Test pressure 400 Pa: The measurement was discontinued without results; a leakage air volume flow could not be detected. Leakage air flow < 0.002 m³/h.
- Test pressure 1000 Pa: 0.009 m³/h (0.0000025 m³/s)

According to DIN 24194, part 1, a leakage air flow of 0.335 10⁻⁶m³/s m² at a test pressure of 1000 Pa results from a surface of the tested individual component of 7.452 m².

According to DIN 24194, part 2 table 1, i.e. VDI 3803 – 4.2.3 tightness, table 7 – the permissible air leakage flow for duct systems with the highest requirements – tightness class IV – at a test pressure of 1000 Pa is 0.27 10⁻³ m³/s m². The measured leakage rate is only one thousandth of the above stated value.

The metal duct SL module system can in combination with the ZK/Cr cellular rubber seal used – at the pressure levels specified in DIN – be described as absolutely leak-proof.

Central Department for Heating and Ventilation Technology

Patent specification



SL MODULE is the patented air duct system for industry and trade.



SL MODULAR DUCT DESIGN

By splitting the straight ducts into the screwed/bolted flat pack design, it was possible to achieve a considerably higher freight capacity compared to conventional ducts.

This makes the SL modular ducts ideal for export.

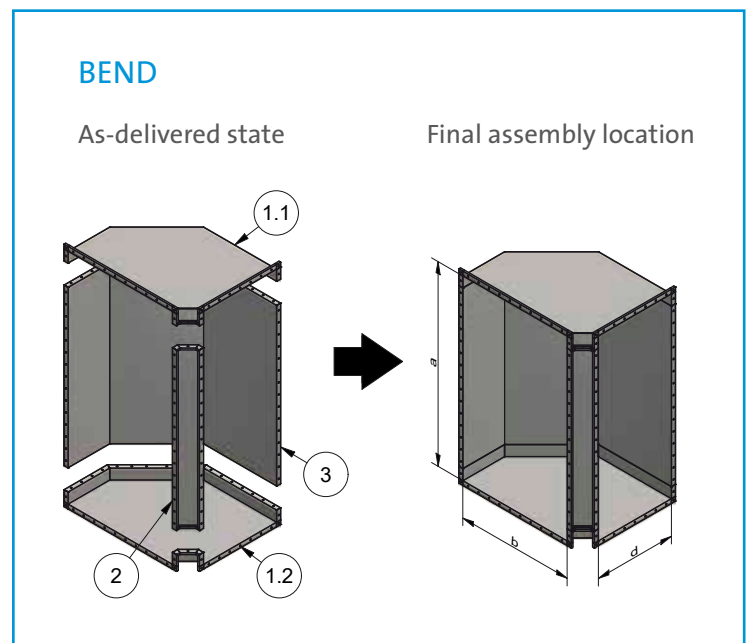
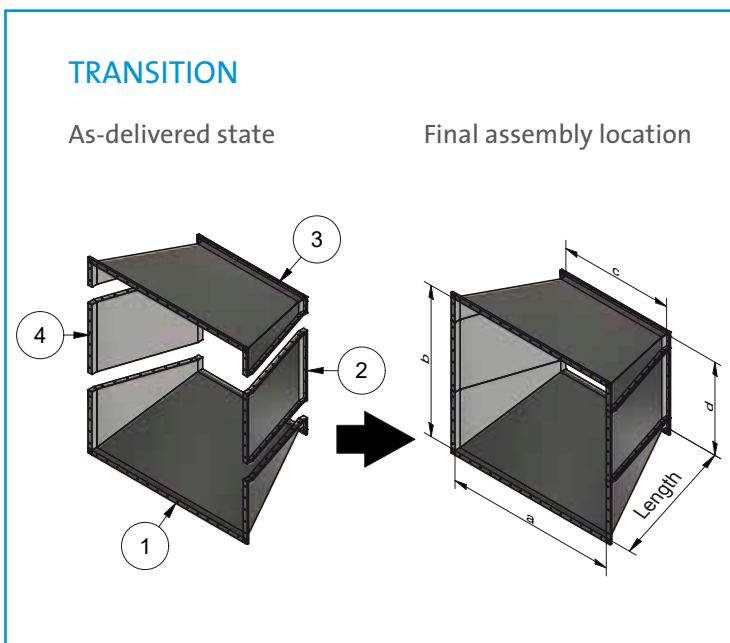
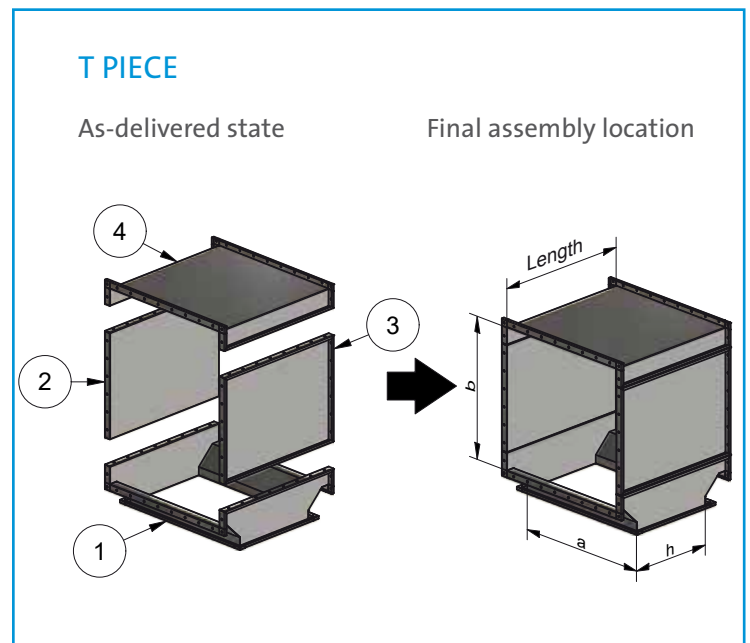
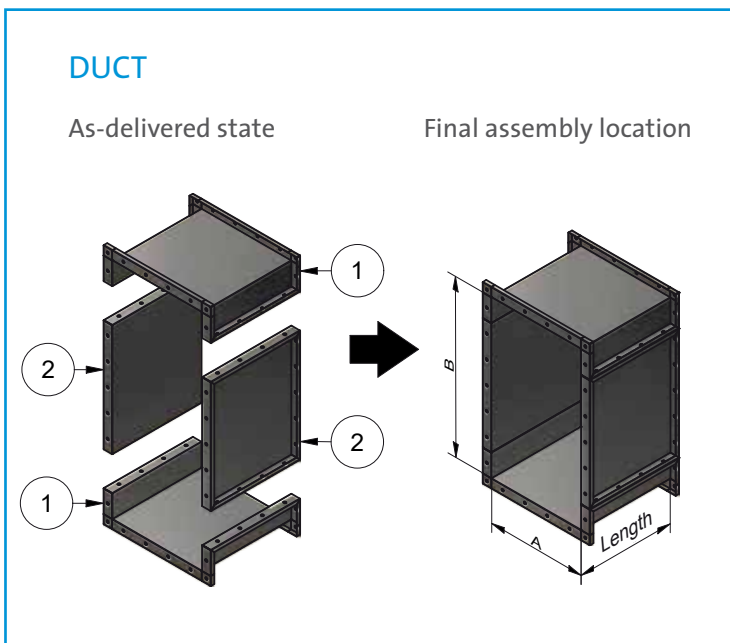

SL MODULAR DUCT FINAL ASSEMBLY BOLTED / SCREWED

The screwed/bolted connections of the duct parts and fittings form the joint flanges and with additional external stiffeners further strengthen the construction of the duct wall.

Screwing/bolting of the panel flanges.

Hole spacing 100 mm for M8 screws.

ADVANTAGES OF BOLTED CONSTRUCTION:

- completely smooth inner duct walls
- optimal corrosion resistance
- large freight capacity thanks to the flat pack panel design
- easy assembly thanks to lightweight individual elements

FLANGE CONNECTIONS:

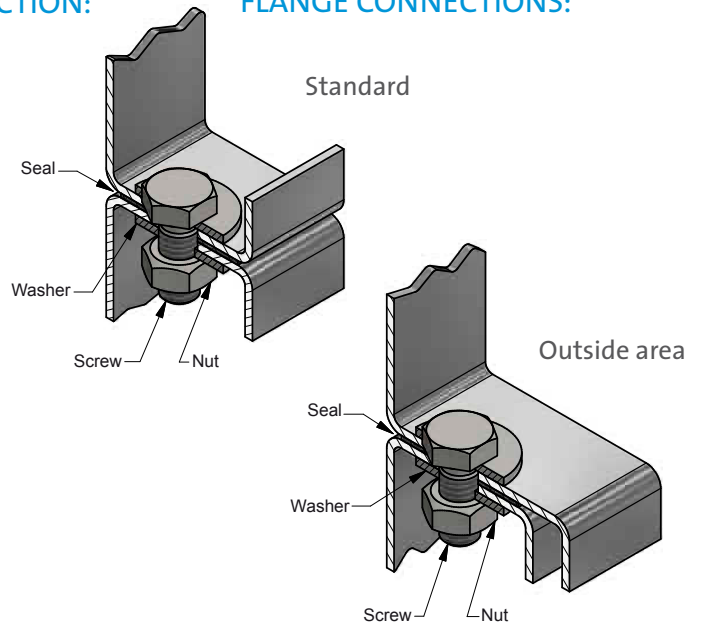

SL MODULAR DUCT FINAL ASSEMBLY WELDED

Joint flanges can be fully welded either internally/externally or both.

ADVANTAGES OF WELDING:

- high tightness and safe installation
- high weld seam quality
- suitable weld seam treatment

FLANGE CONNECTIONS:

If the duct is not accessible from the inside, seal-weld from the outside.

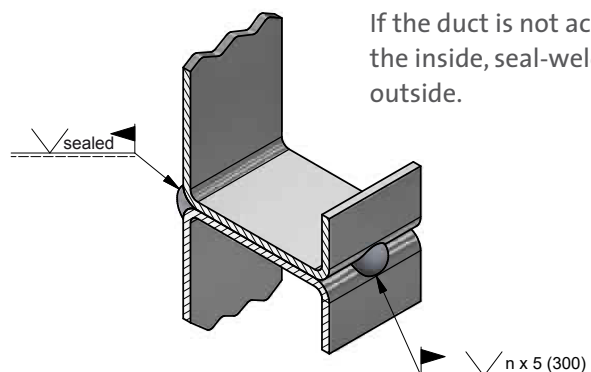

SHEET METAL PIPES WELDED

Material	Material no.
Galvanised steel	DX51D + Z275 MAC (1.0226)
Carbon steel	S235JR + AR
Stainless steel V2A	1.4301 / 1.4307 / 1.4541
Stainless steel V4A	1.4571 / 1.4404
Aluminized	DX51D + AS 120 (1.0226)

Design based on DIN EN 1506
 Dimensions: DN 250 - DN 1600 mm
 Standard length: 3000 mm
 Special dimensions available on request.
 Sheet thickness depends on the pipe diameter, i.e. customer requirements.
 Flanges according to DIN.

FLANGE CONNECTIONS:

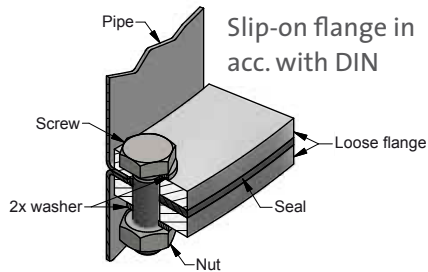
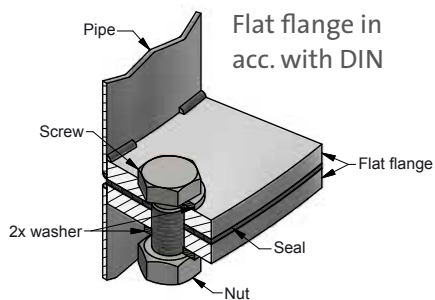

BUSHING CONNECTION:

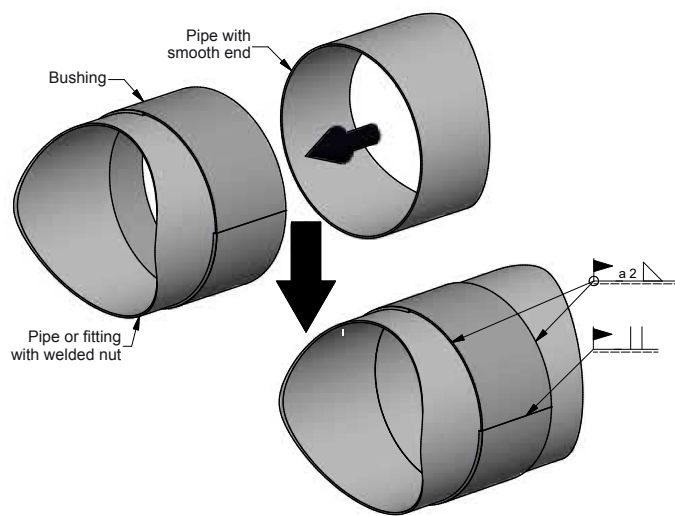

Fittings, as well as accessories are included in our delivery range. Offer on request.



LOCK-SEAM DUCTS

SL lock-seam ducts have a rectangular cross-section made of galvanised steel, for which the sheet quality is specified in DIN EN 10147. The zinc coating amounts to at least 275 g/sqm on each side. The type of lock-seam selected is the so-called Pittsburgh lock-seam or an equivalent other type of lock-seam. The high quality results from the minimum sheet thickness of 0.70 mm on one side, and the tightness class according to DIN EN 1507 on the other.

The longitudinal seams are folded and mounted onto lightweight profile frames; the walls are profiled. The baffle arrangement is in accordance with DIN EN 1505. Additional surface reinforcement is carried out as required, depending on the operating pressure. The standard length for ducts is 1500 mm.

Material	Material no.
Galvanised steel	DX51D + Z275 MAC (1.0226)
Stainless steel V2A	1.4301 / 1.4307
Stainless steel V4A	1.4571 / 1.4404

Maximum pressure capacity for air ducts in accordance with DIN EN 1507

Pressure class	Low pressure (N)	Medium pressure (M)	High pressure (H)
Pressure resistance [Pa]	-500 / +1000	-750 / +2000	-2500 / +6000

Sheet thickness for pressure level low (N)

Edge length in mm	Sheet thickness (mm)
up to and including 500	0.70
up to and including 1000	0.80
up to and including 1400	0.90
up to and including 2000	1.00
above 2000	1.10

FLANGE CONNECTIONS:

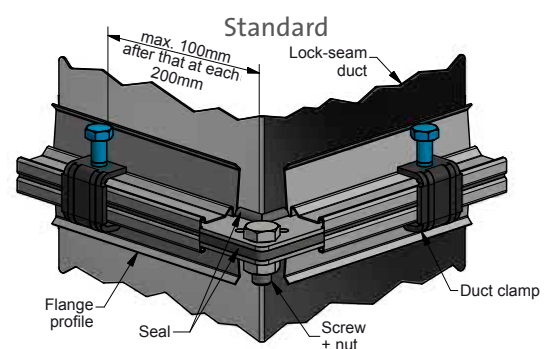

Sheet thickness for pressure level medium (M)

Edge length in mm	Sheet thickness (mm)
up to and including 400	0.70
up to and including 800	0.80
up to and including 1200	0.90
up to and including 1600	1.00
up to and including 2000	1.20
above 2000	1.20 (1.25)

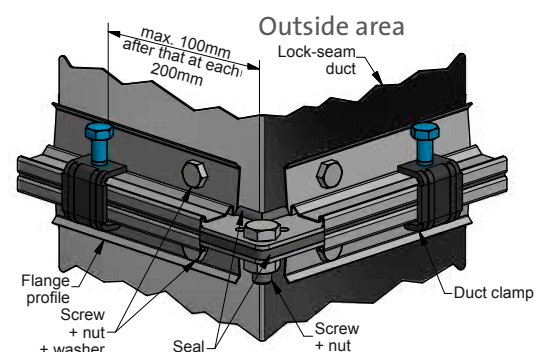

VARIOUS ACCESSORIES COMPLETE THE OFFER

SL INTAKE HOOD

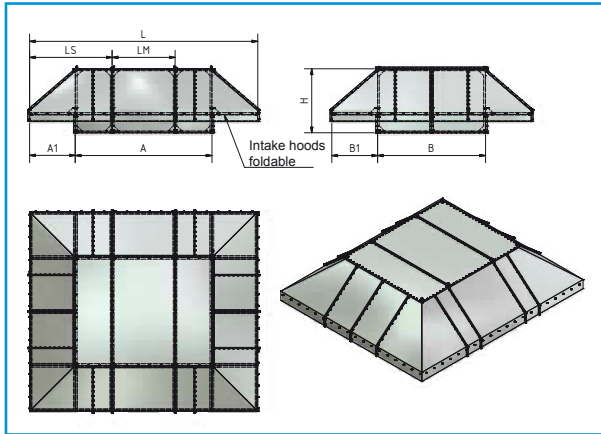

SL DEFLECTOR HOOD

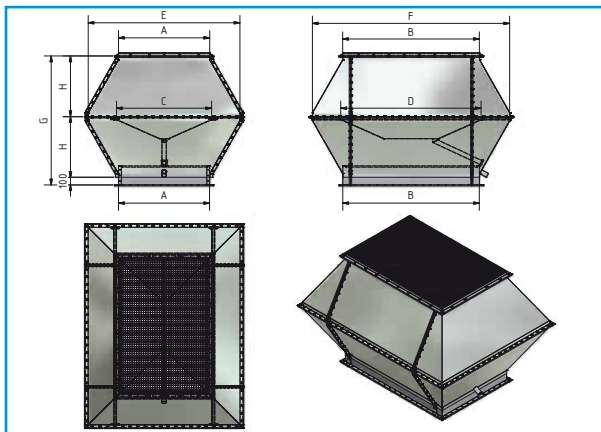

Intake hoods and deflector hoods in modular design.
Both are manufactured according to the customer's request.

SL RAINWATER COLLECTION PIPE

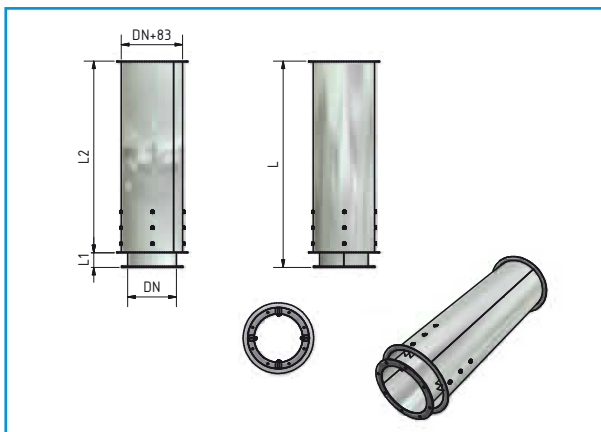

Rainwater collection pipes and roof ducts are manufactured according to
the customer's request.

SL INSPECTION DOOR

- stable, airtight industrial design with double-walled door panel 40 mm thick, available with heat insulation
- stable door frame suitable for installation in SL module duct with flat steel backing flange screwed tightly into the duct wall
- door seal with closed-cell soft-elastic cellular rubber. Application range from -30°C to +90°C
- stable turn bolt, lever length 180 mm, can be operated from the inside and outside. With plastic sticker indicating the "open" and "closed" position

W (min: 400)	H (min: 400)
W (max: 1000)	H (max: 2000)
Material:	VA, galvanised, aluminized
Hinges:	right/left
Pressure in duct	pos./neg.

Special designs available upon request.

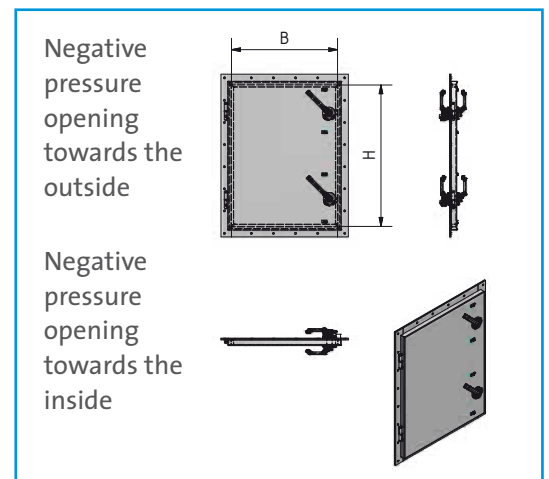

MOTOR-OPERATED AIR VOLUME CONTROL DAMPERS

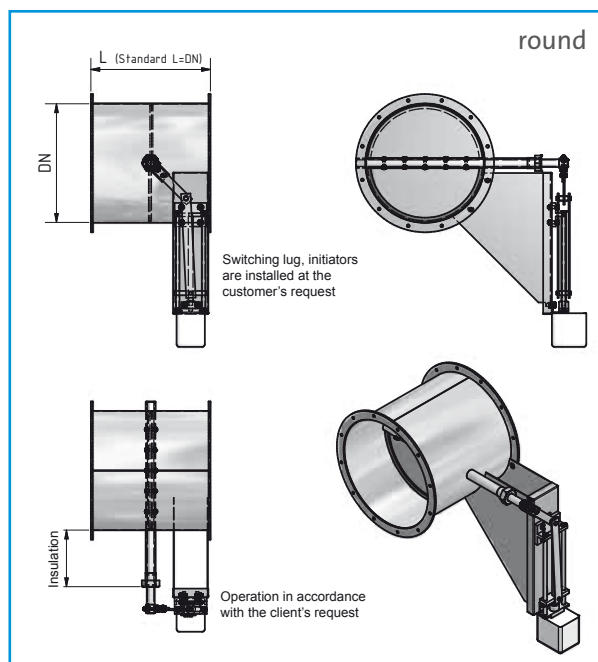

All dampers are manufactured according to customer requirements.

AIR VOLUME CONTROL DAMPERS WITH HANDLE

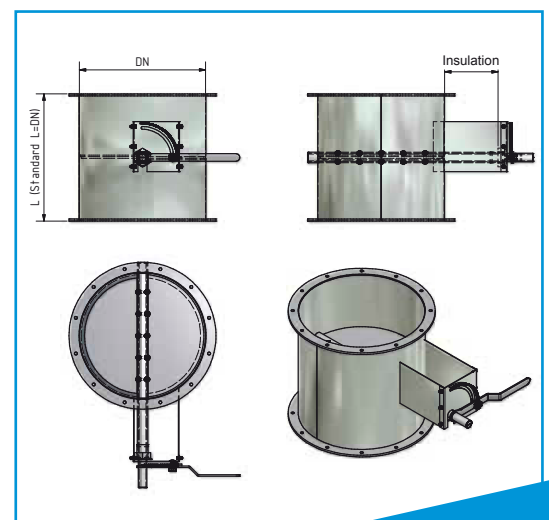

OTHER ACCESSORIES:
actuators, multiflap-dampers, grilles, weatherproof grilles, fire dampers, etc.
on request

SERVICES FOR CUSTOMERS IN THE AREAS OF METAL AND SHEET METAL PROCESSING

In our product segment metalworking, i.e. sheet metal forming, we are experts in complete solutions of highest quality. In addition to the production of air duct systems, we manufacture high-quality laser cut parts and their further processing for products made of sheet steel and stainless steel.

On more than 6,000 m² we offer all technologies of contemporary sheet metal processing:

- Laser-cutting
- Bending
- Welding (WIG/MIG/MAG/plasma)

Contemporary sheet metal processing cut precisely to the required dimensions.



COMPONENTS FOR PLANT ENGINEERING

WORK DECKS

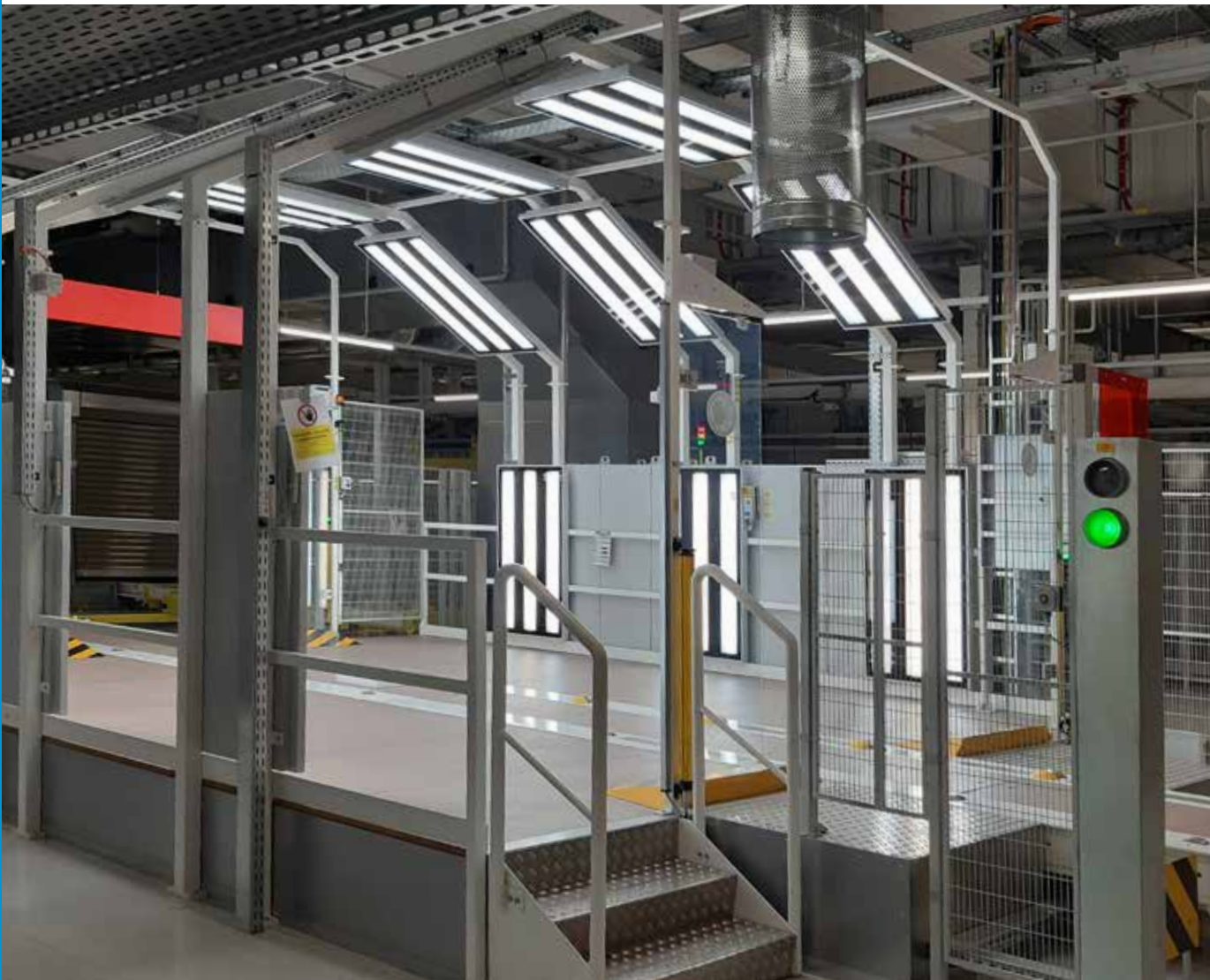

SHEET METAL/CABIN ENCLOSURES



AIR SHOWERS

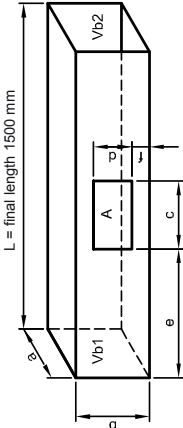
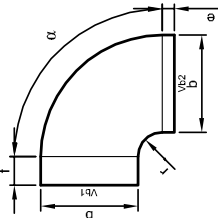
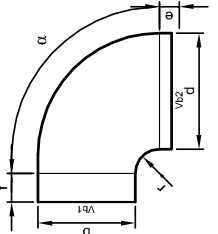
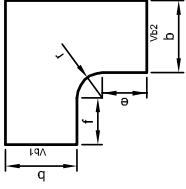
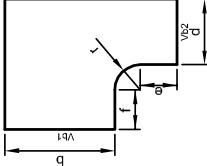
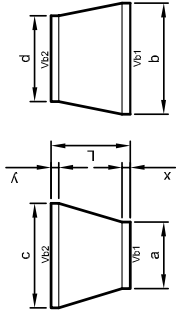
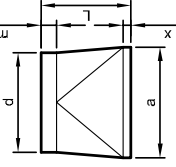
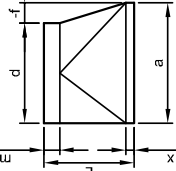
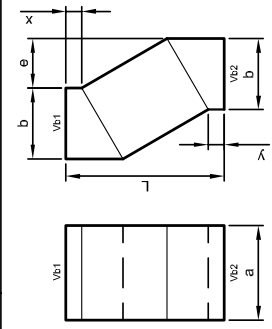
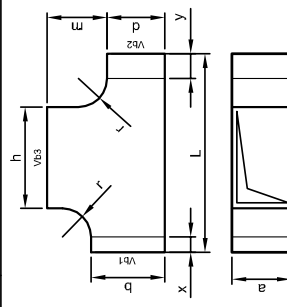
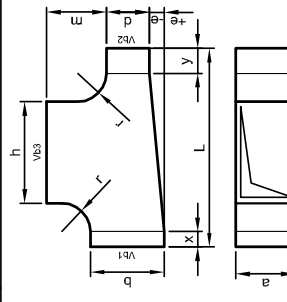
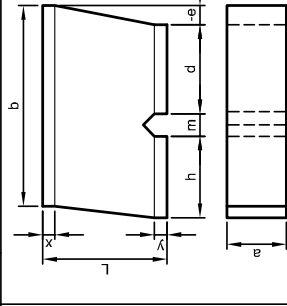
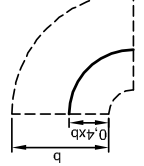
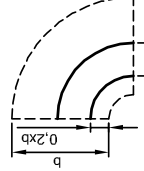
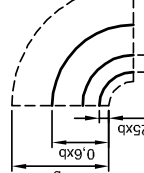

10	Duct	20 Bend	21 Bend Transition	30 Bend Square
10a	Duct with cutout 	20 Bend 	21 Bend Transition 	30 Bend Square 
31	Bend Transition Square	40 Transition symmetrical	50 Transition symmetrical	51 Transition asymmetrical
		40 Transition symmetrical 	50 Transition symmetrical 	51 Transition asymmetrical 
31	Offset	70 T-piece	71 T-piece, transition 80	09 Special fitting
		70 T-piece 	71 T-piece, transition 80 	09 Special fitting 
L	Guide plate * if necessary, state after duct drawing no.!!!	Duct connection with profile flange Pressure level N/1+4 (-630Pa do 1000 Pa) Press. M/N/2+5 (-1000 do 2500Pa)	Duct connections Vb	Manufacture based on drawing
	400≤800 	SB20 edge length < 900 SB30 900 ≤ edge length < 2200 SB40 edge length ≥ 2200	UM 40 Modul 40 drilled B 15.20 Board 15mm, 20 mm (surr. edge 90°) U 15.20 Cover 15-20 mm (surr. edge 180°)	Manufacture based on drawing
	800≤1600 		gI duct end smooth EB end plate IFL plug-in socket (inner) PL fitting length, loose flange	Manufacture based on drawing
	1600≤2000 			Manufacture based on drawing



BE IMPRESSED
BY OUR SERVICES!

SÜDLUFT
SYSTEMTECHNIK

YOUR RELIABLE,
INNOVATIVE PARTNER
FOR VENTILATION TECH-
NOLOGY AND SHEET
METAL PROCESSING

OUR FURTHER BUSINESS AREAS

KITCHEN VENTILATION TECHNOLOGY
(Extractor ceilings and hoods)

VENTILATION TOWERS

VENTILATION COMPONENTS FOR CLEANROOM AREAS

SÜDLUFT

SYSTEMTECHNIK

SÜDLUFT SYSTEMTECHNIK GMBH

Robert-Bosch-Straße 6 | 94447 Plattling | Germany

Tel. +49 9931 9179-0 | Fax +49 9931 9179-770

info@suedluft.de | www.suedluft.de

